

KLP® Hybrid Polymer Main Track Sleeper



- 50 Year Expected Design Life
- Low Life Cycle Costs
- Sustainable Product
- Recycled & Recyclable Materials
- Excellent Damping & High Strength Properties
- High Chemical Resistance
- Sound & Vibration Reduction
- High Lateral & Vertical Stability

Sustainable polymer railway solutions

Lankhorst | *Mouldings*

A trade name of Lankhorst Engineered Products bv

KLP® Hybrid Polymer Sleepers

In 2004 Lankhorst Engineered Products started with the development of the KLP® Hybrid Polymer Sleepers. The ban on creosote and the restricted availability of hardwood were the main drivers for Lankhorst to develop a polymer sleeper which is manufactured out of 100% recycled material as a sustainable and maintenance free alternative to timber sleepers.



The hybrid polymer sleepers have been designed for longevity, not only to reduce the Total Cost of Ownership, but also to maintain continuous track stiffness when used for interspersing with timber sleepers. The KLP® Hybrid Polymer Sleepers are ideal for selective replacement of timber sleepers as well as for use in areas where timber or concrete sleepers are not the most beneficial choice for your track.

In 2006 the first sleepers were installed in track, followed by many installations more ever since. KLP® Hybrid Polymer Sleepers offer you good damping properties as well as optimum stiffness, due to the ductility of the polymer in combination with the strength of the steel. The sleepers keep these properties during its long expected lifespan of over 50 years.



KLP® Hybrid Polymer Main Track Sleeper

Field of application and sleeper types

KLP® Hybrid Polymer Main Track Sleeper

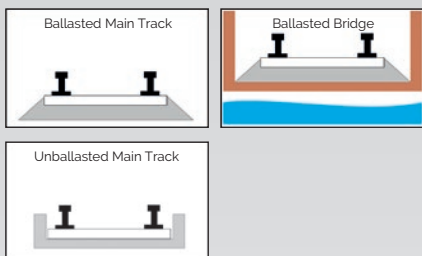

The KLP® Hybrid Polymer Main Track Sleeper has the best stability in the market for polymer-type sleepers nowadays. The innovative polymer sleeper has great lateral resistance due to the profiled bottom of the sleeper. Its recessed design allows for the sleeper to be completely embedded within the ballast, which provides excellent vertical stability against uplift.

The sleeper is manufactured from a high quality, ductile, reinforced polymer with two steel bars encased, which provides both high strength properties as well as excellent damping characteristics.

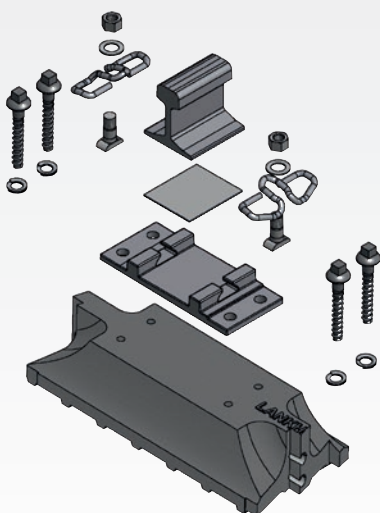
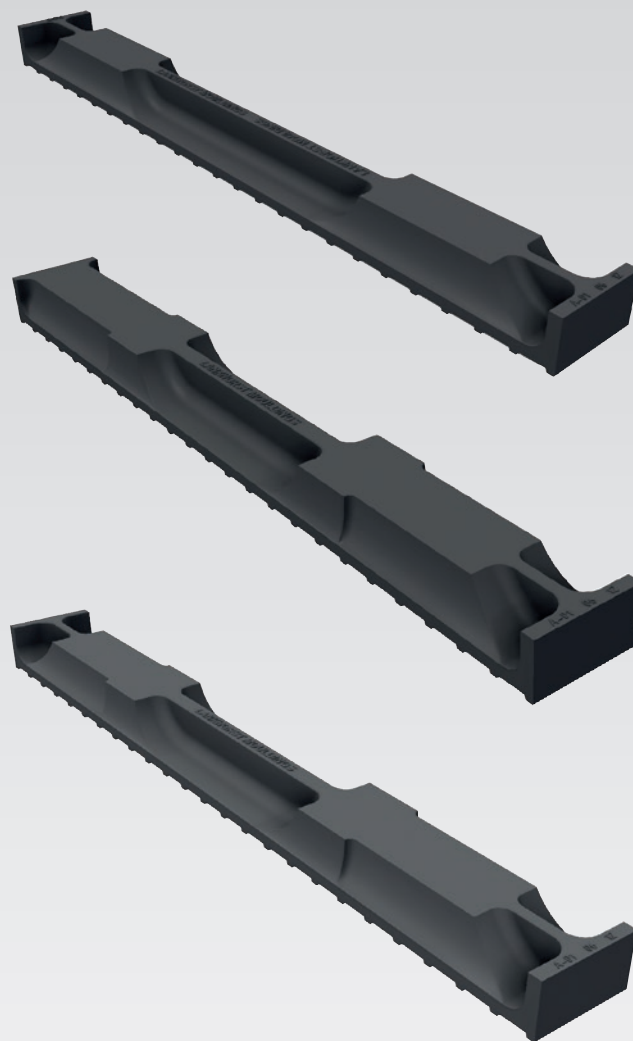

Dimensions, specifications, certificates

Feel free to contact us with your specific request with regard to dimensions, specifications and available certificates in your region. We will gladly assist you with your local type approval process.

KLP® Pre-drilling and Mounting Service

Lankhorst offers you a pre-drilling and mounting service for a faster installation on location. Whether you want pre-drilled sleepers on one or two sides or even if you require pre-mounting of baseplates.

History of Royal Lankhorst Euronete

How it began...

1803 - Nicolaas Jurjan Lankhorst started a rope manufacturing factory in Sneek, The Netherlands. At that time ropes and yarns were made of natural fibers like sisal, hemp, jute and coco yarn.

1964 - A revolution took off in rope and yarn production. Plastics were introduced and by that new yarn and rope types, with a more consistent quality and longer lifetime. The waste materials of the plastic yarn production proved to be useful for a second life.



1975 - Lankhorst started to produce the first plastic molded products.

1986 - Lankhorst Recycling was born. The plastic product program was extended ever since.

1998 - The Portuguese Grupo Euronete and the Lankhorst Group merged into one new Lankhorst Euronete Group.

2003 - Queen Beatrix of the Kingdom of the Netherlands granted the predicate "Royal" to the company

2004 - KLP® Hybrid Polymer Sleepers were developed

2006 - First KLP® Hybrid Polymer Sleeper in track in The Netherlands

Today ...

Since Lankhorst produced its first plastic post through the process of intrusion in the '70s, many innovations have come to maturity. Today Lankhorst has their own Research and Development department capable of designing, calculating and testing products. Lankhorst now serves a variety of markets with large plastic products molded from either recycled plastics or new materials.

Service and Partners

For more information and advise, please consult our website www.lankhorstrail.com/en



Official Service Partner:



Prinsengracht 2
P.O. Box 203
8600 AE Sneek - The Netherlands

T +31 (0)515-487539
I www.lankhorstrail.com/en
E info@lankhorstrail.com

